

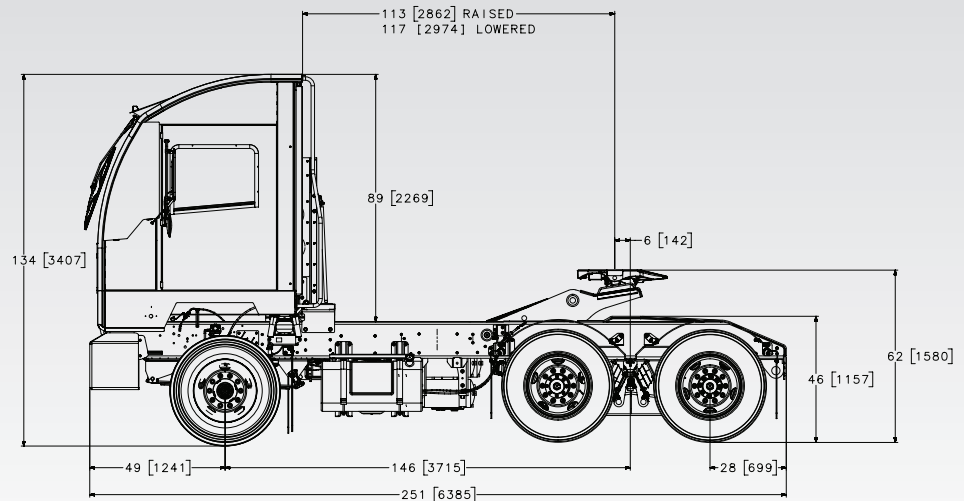

# ACTT 6X4

AUTOCAR TERMINAL TRACTOR - DOT/EPA COMPLIANT

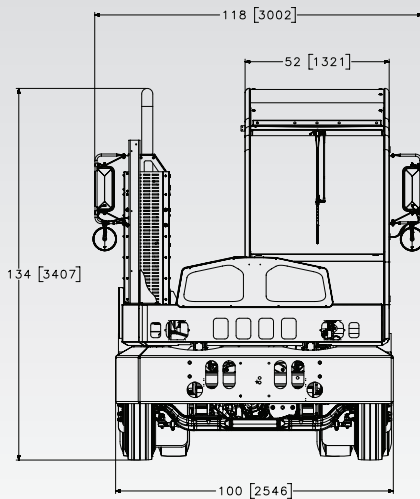

**ACTT 6X4 DOT/EPA COMPLIANT**  
 Representative Terminal Tractor Specifications.  
 Your truck will be custom-engineered for your application  
**ALL DIMENSIONS IN INCHES**

## ENGINE AND EQUIPMENT

ENGINE AND EQUIPMENT	STANDARD	OPTIONAL
Engine model	Cummins B6.7 200HP @2600RPM/520 LB-FT @1500RPM	Cummins B6.7 260HP @2600RPM/620 LB-FT @1500RPM Cummins B6.7N 200HP @26000RPM/520 LB-FT @1500RPM Cummins B6.7N 240HP @26000RPM/560 LB-FT @1500RPM
Exhaust	Vertical single module DPF/SCR; (B6.7 only) right side mounted	
DEF	6 gallon DEF tank	12 gallon DEF tank
Air Cleaner	Donaldson 11 inch single stage	11 inch, 2 stage/Donaldson inline precleaner/Donaldson topspin precleaner/exhaust turn-out
Radiator	850 square inch aluminum	
Fan & Drive	Viscous fan drive	Electric Control Horton RCV250
Coolant Hoses / Piping	Silicone hoses with steel tubing	
Coolant	Extended life coolant	
Engine Equipment	Fleetguard FS 1003 F/W separator w/probe & dash light	Fleetguard FS 1003 with heat/Davco 382 with heat Engine block heater (750/1000W)/oil pan heater/ engine oil sample port Arctic Fox in-tank fuel heater w/thermostat

## TRANSMISSION AND EQUIPMENT

TRANSMISSION AND EQUIPMENT	STANDARD	OPTIONAL
Transmission model	Allison 3000 RDS	Allison 3500 RDS
Transmission gearing	4-speed	3, 4 or 5-speed
Transmission controls	Allison push button	Allison T-handle
Transmission cooler	Oil to water type	
Transmission lubricant	TranSynd™ synthetic	
Driveshaft	Dana Spicer® 1710 half-round	

## FRONT AXLE AND EQUIPMENT

FRONT AXLE AND EQUIPMENT	STANDARD	OPTIONAL
Axle model	Meritor MFS Wide track (14,700 lb rated)	Dana Spicer® E-1322-W (13,200 lb rated)
Front suspension	Flat leaf (14,500 lb rated)	Flat leaf (18,800 lb rated)
Shock absorbers	Double acting - heavy-duty	
Power steering	Gearbox, integral steering w/mechanical backup	
Power steering reservoir	Integral w/hydraulic tank	
ABS	None (exempt)	4S4M w/o traction control
Brakes	16.5 x 5 s-cam	
Brake drums	Cast iron	
Stack adjusters	Meritor automatic slack adjusters	Haldex slacks
Front hubs	Iron hub piloted	

## REAR AXLE AND EQUIPMENT

REAR AXLE AND EQUIPMENT	STANDARD	OPTIONAL
Axle model	Meritor MT40-14X (single reduction)	
Rear axle ratio	7.17:1	
Rear suspension	Hendrickson HN460 54" spread	
ABS	Exempt	4S4M with and without traction control
Brakes	16.5 x 8.62	16.5 x 7
Brake drums	Cast iron	
Stack adjusters	Meritor automatic slack adjusters	Haldex slacks
Rear hubs	Iron hub piloted	
Gear lubricant	Synthetic	

## CHASSIS AND EQUIPMENT

CHASSIS AND EQUIPMENT	STANDARD	OPTIONAL
Wheelbase	146 inch	
Frame	2.0 million RBM, 50,000 KSI steel, C-reinforced	2.0 Million RBM, 50KSI Steel, C-reinforced, heavy duty box frame, galvanized coating
Frame fasteners	Grade 8 bolts where possible	
Bumper	Steel reinforced bumper	Heavy duty reinforced bumper
Tow device(s)	Front & rear tow eyes	
Mud flaps	Rear of drive tires	
Brake system	121 air brake system, front/rear system protection	

## PNEUMATIC SYSTEM (RAPID FILL)

PNEUMATIC SYSTEM	STANDARD	OPTIONAL
Air compressor	Wabco 18.7 CFM	
Air system Drain Valve	Manual petcocks all tanks	air manifold with pull cords in all tanks or 1/4 turn valve tank drains
Air lines	Nylon, color coded	
Brake system	121 air brake system, front/rear system protection	

## FUEL SYSTEM

FUEL SYSTEM	STANDARD	OPTIONAL
Fuel tank	50 gallon steel round mounted left side	50 or 75 gallon step tank, 50 gallon aluminum round, Dual 50 gallon tanks Prep for CNG or LNG tanks (W/ Cummins B6.7N option)
Fuel filter	Cummins	
Fuel lines	SAE J844 nylon	

## 5TH WHEEL & HYDRAULIC SYSTEM

5TH WHEEL AND HYDRAULIC SYSTEM	STANDARD	OPTIONAL
5th wheel	SAF/Holland 80,000 lb semi-oscillating 16 inch lift	SAF/Holland 100,000 lb semi-oscillating 16 inch lift
Hydraulic lift cylinders	(2) 5 inch 50,000 lb capacity, upper & lower spherical bushings	Limited lift height cylinders
Hydraulic tanks	15 gallon steel tank w/sight glass	
Pump	Engine mounted	Chelsea PTO 280-5RK

## TRAILER EQUIPMENT

TRAILER EQUIPMENT	STANDARD	OPTIONAL
Air connections	15 ft straight rubber trailer hoses w/spring hanger	20 ft straight rubber trailer hoses w/spring hanger
7-way electric cable receptacle		12 ft electrical cable, 15 ft electrical cable

## TIRES AND WHEELS

TIRES AND WHEELS	STANDARD	OPTIONAL
Front tires	295/75R22.5 Low-Pro Double Coin	(11R/280/275)/Goodyear, Michelin, Continental
Front wheels	Steel 22.5 x 8.25 hub piloted, 285mm BC	22.5x8.25" Steel 2 HH wheel, customer supplied wheels/tires
Rear tires	295/75R22.55 Double Coin	(11R/280/275)/Goodyear, Michelin, Continental
Rear wheels	Steel 22.5 x 8.25 hub piloted, 285mm BC	22.5x8.25" Steel 2 HH wheel, customer supplied wheels/tires V2B flow through valve caps

# ELECTRICAL SYSTEM

ELECTRICAL SYSTEM	STANDARD	OPTIONAL
Electrical system	12V, negative ground	
Alternator	Delco 160 AMP, 28SI w/remote sense pad mount	Mitsubishi 12V 160 AMP pad mount
Starter	Delco Remy 31MT	Denso 12V
Batteries	(2) group 31 750 CCA (min)/ 1500 CCA total	1900CCA, 2000CCA, 3000CCA, AGM batteries 1800CC, 2300 CCA
Circuit protection	Fused circuits	
Windshield wipers	Single electric (pantograph) intermittent w/washer	
Backup alarm	Non-motion detecting	Motion detecting, CA compliant, or white noise
Horn	Single electric	
Telematics	Autocar Advanced Telematics - full installation	

# LIGHTING

LIGHTING	STANDARD	OPTIONAL
Headlamps	Low/high halogen	LED Headlights, spot-style headlights, direct wired
Backup light, stop & turn signals	LED stop & turn, incandescent backup, shock resistant mount	LED spot lights, alternate positioning
BOC 5th wheel light	Incandescent, shock resistant mount	LED BOC light
Marker and side turn signals	LED	

# PAINT

PAINT	STANDARD	OPTIONAL
Cab	White	(Customer specific colors)
Chassis	Black	(Customer specific colors)
Bumper	Black	(Customer specific colors)
Wheels	White powder coat	(Customer specific colors)

# OPERATORS CONTROLS

OPERATORS CONTROLS
Park brake - push/pull
Headlamps
Turn signal - column mounted
Brake pedal (dual pedal optional)
Accelerator pedal
5th wheel height control
5th wheel lock
Transmission gear selector - Push button

CAB INSTRUMENTATION
Cluster with Information/Diagnostic display
Speedometer
Engine oil pressure
Coolant temperature
Transmission oil temperature
Fuel level/DEF level
Primary (A) air pressure
Secondary (B) air pressure
Hour meter
Voltmeter

CAB WARNING DEVICES
Park brake
High beam
Turn signal
Low fuel
Low air
Seat belt
DPF
HEST
Air restriction indicator
Filter with water in fuel indicator
Fifth Wheel height indicator/lock indicator (optional)

# CAB AND EQUIPMENT

CAB AND EQUIPMENT	STANDARD	OPTIONAL
Cab construction	Electrocoated (e-coated) steel, full cab immersion (rust prevention coating)	
Cab dimensions (outside)	Raised roof, 52" wide x 71" deep (w/o rear door) x 78" high (deck to roof)	
Cab doors	Left side hinged door w/manual crank window, aluminum sliding rear door	rear door protector
Rear door opening (useable)	24" wide x 72" high	
Cab floor	Sweep out floor w/durable mat	
Cab dash	Steel wrap around	
Overhead console	Steel	
Cab mounting	4 point, rear dual (2) air suspensions	3-point spring
Cab tilt	Electric over hydraulic	
Windshield	Tinted, laminated windshield	
Rear glass	Tinted, tempered	Laminated, premier high impact-resistant window
Mirrors	Dual SST west coast mirrors	Heated primary, motorized primary, convex
Cab climate control system	44,000 BTU fresh air heater	Air conditioning
Steering column	Fixed	Tilt/telescopic
Steering wheel	18 inch 2-spoke	
Seat	Air suspension, mid-back without fore/aft isolation	air suspension, mid-back with fore/aft isolation
Seat covering	Black Cordura Plus® cloth fabric	Vinyl seat cover
Seat belt	3-point orange extended length	
Dome light	Switch on dash	
Power ports	(1) 12V & 2 USB	
Air horns		Mounted R/S top of cab
Translucent sun visor	Translucent-single	
Conspicuity tape	White BOC, red/white end of frame	

# ACTT 6X4

AUTOCAR TERMINAL TRACTOR - DOT/EPA COMPLIANT

## OPTIONAL EQUIPMENT

Air Dryer (ADIP, AD-9, Wabco1200)
Fuel/water separator w/heater
Engine block heater
Oil pan heater
Beavertail/frame extension/kingpin guides
Front axle mudflaps
Rear axle mudflap (front)
Rear flexible fenders
Fender skirt/splash protector
Glad hand buckets
Additional engine tunnel insulation
360 degree swivel trailer light
Premium seating options (swivel, heated)
Rear axle differential lock

Glad-hand and 7-way cable storage
Battery disconnect switch
Air restriction indicator w/ dash light
Amber beacon light
Spot/work/flood lights
Rear door laminated glass or high impact resistant window
Training seat
Auto lube systems
Trailer stops/full cab guard
Dock bumpers (cab)
Additional decking, side cab catwalk
Diamond plate cab floor
RH deck access steps
Dollymaster, pintle hook options
Trailer hand brake

Cab fan(s)
AM/FM radio/CD w/ aux input, speakers & antenna
5# ABC fire extinguisher
Triangle kit
Lever start, no key/pushbutton start
Double blink strobe light, other strobe/beacon options
Air horn
No driver door
Lever start, no key/pushbutton start
Double blink strobe light, other strobe/beacon options
Trailer rapid fill system
Pneumatic 5th wheel lockout
Cab document storage
RH deck access steps
Autocar autopark system

## BASIC WARRANTIES (INDUSTRY BEST)

ENGINE AND EQUIPMENT	STANDARD	OPTIONAL
Autocar terminal tractor	1 year or 3,000 hours whichever occurs first, parts & labor	
Frame	7 years or 20,000 hours whichever occurs first	
Cummins engine	B6.7- 3 years parts & labor (2,000 hours)	
Allison transmission	3 years parts & labor	5 year optional
Dana axles	3 years parts & labor	
Meritor axles	(24-160 only) 6 months, parts only	2 years parts & labor

## VEHICLE RATINGS

Vehicle tare weight, front	
Vehicle tare weight, rear	
GAWF	14,500 lbs
GAWR	40,000 lbs
GCW	80,000 lbs